

APPROVAL SPECIFICATION

PRODUCT NAME:

KOOMAG PN:KMTC0830 Series

CUSTOMER PN:

CUSTOMER RESPONSE

<input type="checkbox"/> Approval <input type="checkbox"/> Approval with the following changes <input type="checkbox"/> Reject		
APPROVED BY	SIGNATURE	DATE

KOOMAG ENGINEERING SIGNATURE

APPROVED BY	CHECKED BY	ISSUED BY
DATE	DATE	DATE

深圳坤磁科技有限公司

SHENZHEN KOOMAG TECHNOLOGY CO., LTD

Address: B503, Building B, HuaChuangDa Headquarters Building, Bao'an 49 District, Shenzhen

General Description

This specification applies to the KMTC0830 Series of wire wound SMD power inductor.

Appearance & Shape

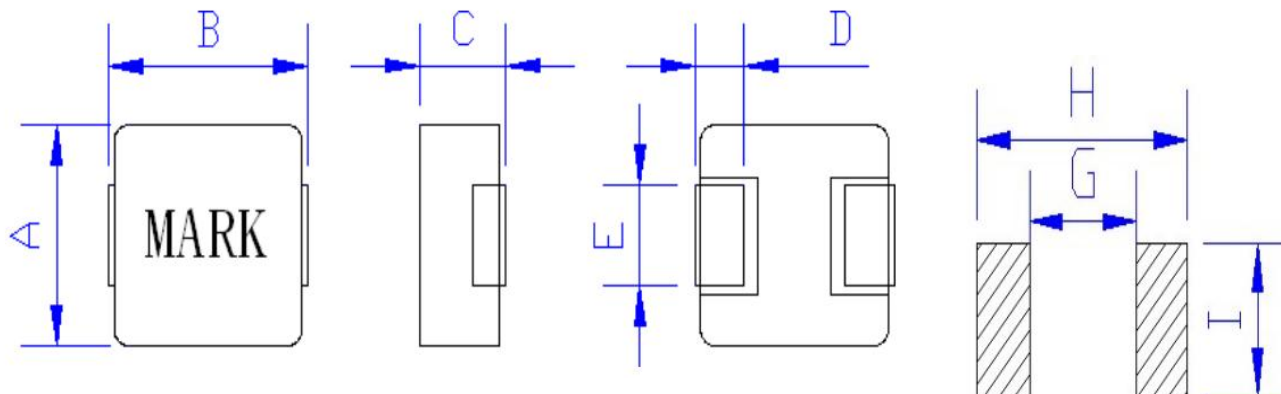

Dimension (Unit:mm)

NO	Series	A	B	C	D	E	G	H	I
1	KMTC0830	8.0 ±0.3	8.7±0.5	3.0 Max	1.8±0.5	3.0±0.3	4.5 Ref.	9.0 Ref.	3.5 Ref.

Part Number

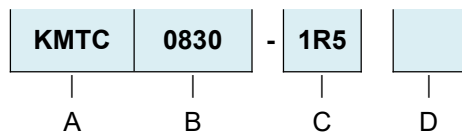

A:Series name (产品品名)

B:Dimensions (产品尺寸)

C:Inductance value (电感值) 1R5: 1.5μH 220: 22μH

D:Tolerance (误差值) K: ±10%; M: ±20%; N: ±30%

Electrical Characteristics

Please refer to Item 5.

- 1). Operating temperature range (individual chip without packing): $-40^{\circ}\text{C} \sim +125^{\circ}\text{C}$.
- 2). Storage temperature range (packaging conditions): $-40^{\circ}\text{C} \sim +85^{\circ}\text{C}$ and RH 70% (Max.).
- 3). Rating DC current: Temperature rise(ΔT) is 40°C approximately at Irms.
- 4). Saturation DC current: Inductance drop approximately 30% of L0 at Isat.

NO	Part Number	Inductance	DC Resistance		Saturation Current	Temp.Rise current	Marking
		100KHz/1.0V	Max.	Typ.	Typ.	Typ.	
	Units	(μH)	m Ω	m Ω	A	A	
1	KMTC0830-R47M	0.47 \pm 20%	5.0	3.1	30.0	21.0	R47
2	KMTC0830-R68M	0.68 \pm 20%	4.0	3.6	20.0	16.0	R68
3	KMTC0830-1R0M	1.00 \pm 20%	6.0	4.6	20.0	13.0	1R0
4	KMTC0830-1R5M	1.50 \pm 20%	9.0	6.3	16.0	10.0	1R5
5	KMTC0830-2R2M	2.20 \pm 20%	15	10	14.0	8.0	2R2
6	KMTC0830-4R7M	4.70 \pm 20%	32	24	10.0	6.0	4R7
7	KMTC0830-8R2M	8.20 \pm 20%	60	50	7.0	4.0	8R2
8	KMTC0830-100M	10.00 \pm 20%	60	54	6.5	4.0	100
9	KMTC0830-150M	15.00 \pm 20%	106	95	5.0	4.0	150
10	KMTC0830-220M	22.00 \pm 20%	120	100	4.5	3.0	220
11	KMTC0830-470M	47.00 \pm 20%	290	260	2.5	2.0	470
12							
13							
14							
15							
16							
17							
18							
19							
20							

※Design as Customer's Requested Specifications. (可按顾客的特殊需求设计)

■ Packaging(unit:mm)

1.Tape Dimensions(Unit:mm)

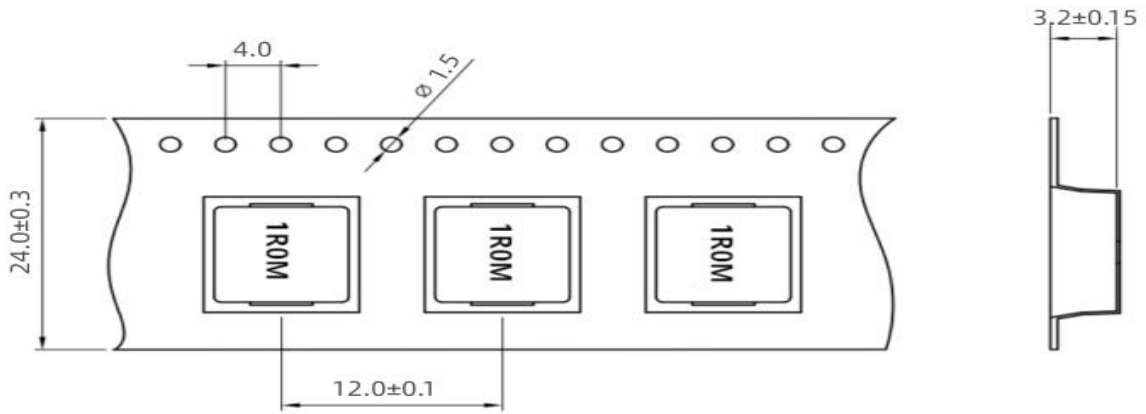

2.Reel

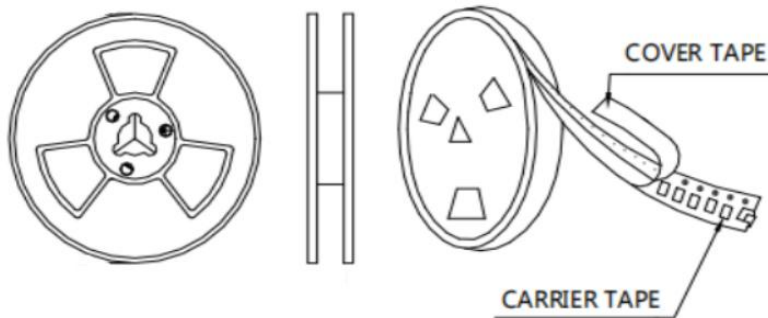

Part No.	Tape	MPQ
KMTC0830	Embossed Tape	1000PCS

Soldering Condition Sproduct

Applicable soldering process to the products is refl.

1.Soldering Materials

(1)Solder:Sn-3.0Ag-0.5Cu

(2)Flux:Use rosin-based flux,but not strongly acidic flux (with xhlorine exceeding 0.2wt%).Do not use water-soluble flux.

2.Reflow Soldering Profile

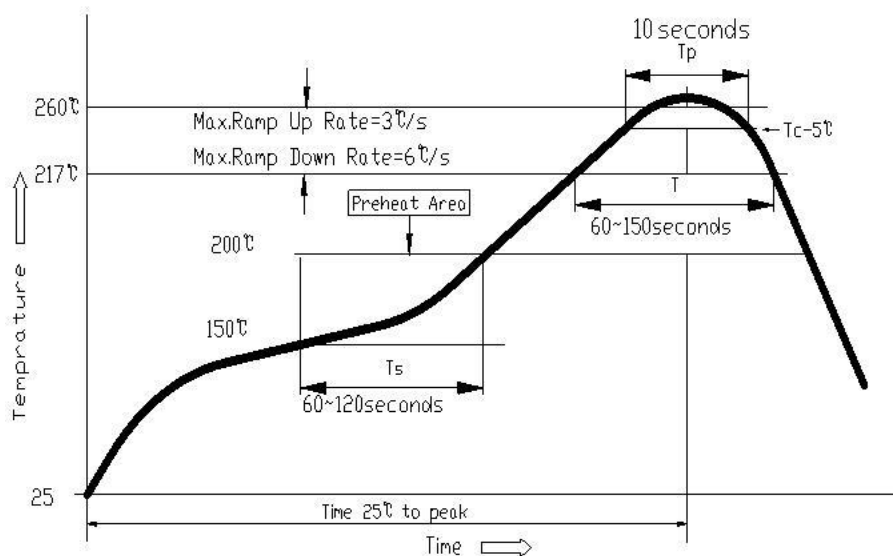

3.Solderin glron

Reworking with electric soldering iron must preheating at 150°C for 1 minute is required,and do not directly touch the core with the tip of the soldering iron.The reworking soldering conditions are as follows.

- ①Temperature of soldering iron tip:350°C ;
- ② Soldering iron power output:≤30W;
- ③ Diameter of soldering iron end:≤1.0mm;
- ④Soldering time:< 3s.

